Experiment

INTRODUCTION TO CALORIMETRY

The CCLI Initiative

Computers in Chemistry Laboratory Instruction

LEARNING OBJECTIVES

The objectives of this laboratory are to . . .

- understand the concept of heat and joules.
- perform heat-gain and heat-loss calculations.

BACKGROUND

Heat loss and heat gain

Practically all chemical reactions either release or absorb energy, often in the form of heat. The study of heat and energy changes associated with chemical reactions is known as thermodynamics. This experiment is designed to introduce you to some of the techniques and concepts associated with measuring heat during experiments

Heat can be measured in a wide variety of units. A British thermal unit (BTU) is commonly used in engineering and is the amount of heat required to raise the temperature of one pound of water by one degree Fahrenheit. Similarly, the calorie is the amount of heat required to raise the temperature of one gram of water by one degree Celsius. In science, we most commonly use the unit of heat known as the joule (J). It takes 4.184 joules to raise the temperature of one gram of water by one degree Celsius (One cal = 4.184 J).

One of the important techniques which you will study in this experiment is known as calorimetry. A calorimeter is a device used to measure changes in heat within a system. It must be well insulated from the surroundings so that the heat changes for the reaction occurring within the system may be measured quantitatively.

The Law of Conservation of Energy implies that within the calorimeter the heat lost by one substance must be equal to the heat gained by something else within the system. Substances differ in the amount of energy required to change their temperature. The specific heat of a substance is defined as the quantity of heat required to change the temperature of one gram of the substance by one °C. For example, the specific heat of water is 4.184 J/g °C.

Heat associated with a physical change

Models help us to understand chemical and physical phenomena. For example, we use models to "visualize" molecules. Using a model, what is happening to the molecules of water in a cup when it is heated? We can visualize that the warmer molecules are moving at a greater velocity than the cooler

molecules and so are colliding more frequently with their neighbors. During a phase change such as going from a solid to a liquid or a gas, the molecules dramatically increase or decrease in velocity.

Consider the differences in the properties of ice (solid phase) and water (liquid phase). The phase change between ice and water can be produced by simply heating the ice. When chemists visualize ice, they imagine that the molecules are in a closely packed configuration. In ice, the molecules are relatively immobile. When ice is melted by the addition of heat, part of the heat goes toward overcoming the forces holding the water molecules together as a solid. The amount of energy required to melt a mole of solid (known as the heat of fusion) is a characteristic value for each substance.

Heat associated with chemical change

Many of the chemical reactions that occur spontaneously liberate heat. Chemists and engineers, in fact, are often more interested in the heat liberated in reactions than in the particular chemical products being formed. The heat can be used directly or can be converted in various ingenious ways into useful forms of work or energy.

Combustion of natural gas (methane) in a water heater or furnace is a common exothermic (heat-producing) reaction:

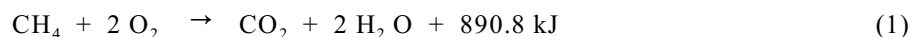

According to the reaction, 890.8 kJ of heat are produced upon the oxidation of one mole (16 grams) of methane.

Not all oxidation reactions proceed rapidly and vigorously by combustion. In living organisms, oxidation reactions proceed much more slowly and at rates controlled by enzymes. These reactions are also accompanied by the liberation of energy (or heat). Some of the energy liberated is used to maintain temperature in warm-blooded animals. Some of it is used for other vital processes, such as muscle contraction, transmission of nerve impulses, and synthesis of essential compounds. When glucose (a type of sugar) is used in metabolism, the oxidation reaction can be written as follows:

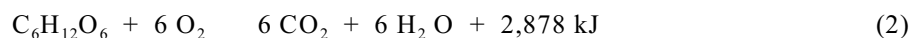

We often refer to the amount of energy "in" a given portion of food. As the reaction shows, there are 2,878 kJ of energy "in" one mole of glucose. The minimum daily requirement of adult humans is about 8,300 to 12,500 kJ, the precise amount depending on how large and how active the individual might be. This is the equivalent of 2,000 to 3,000 food calories.

If our diet provides a potential supply of energy in excess of physical and mental needs, a part of the surplus may be stored as lipids (fats) and, to our dismay, we may become undesirably plump. Conversely, if we expend more energy than we take in, we will become thinner!

One of the many services performed by chemists is that of determining the amount of energy given off when foods, fuels, and other materials undergo oxidation. This determination is usually carried out in a device called a bomb calorimeter (see Figure 1). A sample of the material is compressed into a small pellet and accurately weighed. It is placed in a steel-jacketed container. The air in the container is then flushed out and replaced with pure oxygen gas. The container is then completely immersed in a known

amount of water. The sample is then ignited by means of an electrical ignition wire. Upon ignition heat is evolved, which causes the temperature of the surrounding container and water to rise. By measuring the rise in temperature, it is possible to determine quantitatively the amount of heat liberated in the burning process.

In this experiment, we will use a simplified version of the above calorimeter to investigate energy changes.

SAFETY PRECAUTIONS

Use caution around the burning candle!

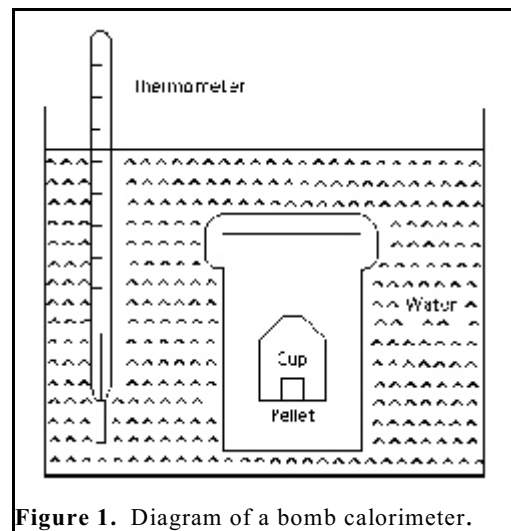

Figure 1. Diagram of a bomb calorimeter.

BEFORE PERFORMING THIS EXPERIMENT . . .

. . . you will need a *MicroLAB* program capable of measuring and displaying temperature. An example of one will be found in the **Temperature Time** tab labeled **heat of solution**

EXPERIMENTAL PROCEDURES

Heat loss and heat gain

In this portion of the experiment, you will account for the energy changes associated with the mixing of hot and cold water. A calorimeter can be used to isolate these energy changes so that we can actually measure them. Styrofoam cups make excellent calorimeters. Because they are good insulators, Styrofoam cups absorb almost no heat. Therefore, Styrofoam cups can be used to "contain" energy changes.

1. Determine the mass of an empty foam coffee cup on a top loading balance.
2. Place about 30 mL of cold tap water into the cup. Add a little ice to the water so that when it is melted, the temperature will be below room temperature (try for around 10 to 15 °C). Determine the total mass of the water and the coffee cup.
3. Place approximately 30 mL of hot water (about 10 to 15 °C above room temperature) into a second coffee cup. It is necessary to know the exact mass of the hot water in the coffee cup, but this may be determined in different ways. You may determine the mass of hot water in the cup now, or wait until the end of the experiment. *You* decide!
4. Start the *MicroLAB* program and measure the temperature of the hot water in the cup using the temperature probe. Collect data for several minutes. Then, with the program still running, quickly transfer the temperature probe to the cold water and measure the temperature of the cold water for several minutes.
5. Quickly, but without splashing, add the hot water to the cold water cup, while stirring it gently with the thermistor, and record the equilibrium temperature. You will need the masses of the hot and cold water and the temperature changes to later perform the data analysis.

Heat associated with a physical change

1. Determine the mass of a dry foam coffee cup. After weighing, add about 100 mL of tap water. Determine the mass of the cup and water.
2. One of you obtain approximately 10 g of ice. Your instructor will show you how to estimate a 10 g quantity of ice. Remove the water from the ice by blotting the ice with a paper towel. .
3. While the one student is preparing the “dried” ice, the other should start the MicroLAB program and, using the temperature probe, be measuring temperature of the water.
4. After several minutes of measuring the temperature of the water in the Styrofoam cup, and after the ice is “dried”, add it to the water in the Styrofoam cup. Be careful not to tip the cup over while doing this addition.
5. While the ice is melting, determine the mass of the coffee cup, water, and ice.
6. Stir the ice and water with the temperature probe the ice is completely melted and the temperature levels off or begins to rise again.

Heat associated with chemical change

In this part of the experiment, you will determine the heat of combustion for candle wax. The combustion of candle wax results from a chemical reaction or chemical change. During this experiment, some wax will melt as well as combust. To avoid losing the mass of any of the melted wax, it is a good idea to weigh the candle on a weighing boat, then keep the boat under the candle while it's burning. At the end of the experiment, weigh the candle and the weighing boat once again.

1. Set up a ring stand with a clay triangle to hold the metal cup (see Figure 2). The cup will serve as a water container.
2. Clean as much carbon off the metal cup as possible, dry it well, then find its mass. Place about 50 mL of cold water in the cup, then re-weigh the cup to find the mass of the water in the cup. The temperature of the water need not be any certain value, but the temperature should be carefully determined and recorded.
3. Weigh a candle and paper towel together. Using a clamp, position the candle with the wick about 1 inch below the cup. Make sure the paper towel is in a position to catch any dripping wax.
4. Light the candle. Stir the water gently with the thermistor until a 10 - 20 °C temperature rise is noted. Record this temperature.
5. Blow out the candle. Allow the molten wax to solidify. Weigh the candle and paper towel to determine the mass of candle burned.

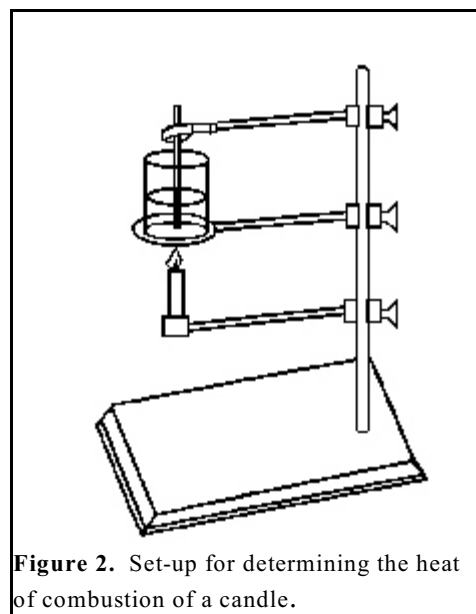

Figure 2. Set-up for determining the heat of combustion of a candle.

DATA ANALYSIS

Heat can be represented by the variable q . In this experiment, you did not actually measure heat; you measured temperature. The heat change in the calorimeter is related to the amount of water you have and the temperature change. In mathematical form,

$$q = s \times m \times T \quad (1)$$

where q is the number of joules absorbed by the water, s is the specific heat (for water, “ s ” is 4.184 J/g °C), m is the mass of water, and T is the change in temperature (e.g. 20 °C).

Heat loss and heat gain

1. Determine the amount of heat gained by the cold water by using equation (1). Note that T is the difference between the temperature after mixing and the temperature before mixing.
2. Determine the amount of heat lost by the hot water. Note that in this case, T is the difference between the temperature *before* mixing and the temperature *after* mixing.
3. Compare the number of joules of heat gained by the cold water to the number of joules of heat lost by the hot water. What conclusions can you draw?

Heat associated with a physical change

1. Determine the heat lost by the water. Below is an example to guide you in this calculation.

Example: Heat loss calculation

Coffee cup and water	102.0 g
Coffee cup	<u>2.0 g</u>
Mass of water	100.0 g
Coffee cup, water, and ice	112.0 g
Coffee cup and water	<u>102.0 g</u>
Mass of ice	10.0 g
Temperature before ice added	25.0 °C
Temperature of final mixture	<u>15.5 °C</u>
Change in water temperature	9.5 °C
Temperature of final mixture	15.5 °C
Temperature of ice added	<u>0.0 °C</u>
Change in ice temperature	15.5 °C

Actual calculation:

(specific heat) (mass H₂O) (temperature = heat loss)

$$(4.184\text{J/g } ^\circ\text{C})(100.0\text{ g})(9.5\text{ } ^\circ\text{C}) = 3.9 \times 10^3\text{ J}$$

2. The amount of heat gained by the ice sample will equal the amount of heat lost by the water. This heat gain is divided into two parts:
- the amount of heat required to change the ice to liquid water at 0 °C; and
 - the amount of heat required to change the temperature of the cold water from 0 °C to the final solution temperature.

Example: Heat gain calculation

- Since; heat lost by the water = heat gained by the ice,
the total heat gained by the ice is: $3.9 \times 10^3\text{ J}$
- The amount of heat required to change the temperature of the cold water from 0 °C to the final temperature is:
 $(4.184\text{ J/g } ^\circ\text{C})(10.0\text{ g})(15.5\text{ } ^\circ\text{C}) = 6.49 \times 10^2\text{ J}$
- Subtracting, (1) - (2), the amount of heat required to melt the ice is:
 $3.3 \times 10^3\text{ J}$
- The amount of heat required to melt one gram of ice is: